



Exaltation of the Holy Cross

Ukrainian Catholic Parish

Українська Католицька Парафія Воздвиження Чесного Хреста

Sundays:

- 9:30 am Rosary
- 10 am Divine Liturgy

Wednesdays:

- 9 am Divine Liturgy

Most Major Feasts*:

- 10 am or 7 pm Divine Liturgy

(* It's always best to check the calendar in this bulletin for upcoming special events & feasts.)

Pastor: Fr. Bo Nahachewsky

780-340-3726 (call or text)
fr.nahachewsky@eeparchy.com

Deacon John Lukey

johndebbielukey@yahoo.ca

Church Website:

EHCUCP.CA

Facebook: facebook.com/ehcucp

Church Email: office@ehcucp.ca

Pastoral

Emergencies: 780-340-3726

Church: 780-478-5260

Hall: 780-478-4275

Fax: 780-476-6485

Eparchy: 780-424-5496

Church Address:

9003 - 153 Avenue NW
Edmonton, AB

Church Mailing Address:

Londonderry P.O. Box 70029
Edmonton, AB T5C 3R6

More info on the next page.

Sunday, June 9, 2024

Third Sunday after Pentecost. Octoechos Tone 2.
Our Holy Father Cyril, Archbishop of Alexandria (444). Apostles' Fast.



Saturday, June 22

Put on by **LEGENDS CATERING**
Entertainment by St. Albert DanceCo Ukrainian Dancers
Live music by "Mike and the Relics"

For Adults Only - \$50 / person
For Tickets call Lisa at 780-222-9155

We shall bless our Parish Pastoral Council (PPC) after Liturgy today.

Almost every parish has a group of people who are elected annually to serve the needs of the parish. These people are called the Parish Pastoral Council. Many of the people who were on it last year remain, but there were a few changes. Since Fr. Bo did not think of it earlier (...there are lots of things Fr. Bo forgets), we will be officially blessing the new group today after our Liturgy.

Although the elected PPC was voted on during the Annual General Meeting, we still rely on volunteers like you, with a variety of gifts and talents, to serve on many different Committees. These committees and subcommittees do everything from taking care of the building or it's finances, to making sure there is bread available for the upcoming liturgical services or cream for the coffee hours.

If you would be able to help the parish in any way big or small, come and introduce yourself to a member of the PPC. We would all be happy to help you find your niche(s) in this, your parish.

If you wish to know who is on our PPC, look on page 2 of this bulletin, the full council is listed there in the sidebar.

Hall Rentals:

call Lisa at: 780-222-9155
 or email: hallrental@ehcucp

Perohy Off Sales: 780-478-4275

Membership:

email: membership@ehcucp

Funeral Dinners:

Call Cheryl: 780-456-2828

Reminder: To receive member rates for funerals/memorials the deceased person must have been a fully paid up member of Holy Cross Parish for the past 22 consecutive months. Deceased children of fully paid up members are also entitled to member rates however child must be a dependant or under the age of 18.

Parish Pastoral Council:

Parish Priest – Fr. Bo Nahachewsky
 Deacon - Dcn. John Lukey
 President – Mark Helmak
 Past President – Peter Fedorak
 1st Vice-President – Mark Ramsankar
 2nd Vice-President – Deacon John Lukey
 Secretary – Gwen Uchach
 Treasurer – Dale Kluk
 Archivist – Diana Horyn
 Cultural – Maryka Bodnar
 Fundraising – Terry Yackimec
 Hall Rental – Lisa Borosuik & Gladys Woitas
 Ladies' Club – Diane Kluk
 Knights of Columbus – Darrell Uchach
 Men's Club President – Marc Chiasson
 Youth Coordinator – Emmette Lysak
 Maintenance – Larry Waye
 Membership – J'lyn Ramsankar
 Social – Edd Horyn
 Spiritual – Elizabeth Podloski

Baptism, Chrismation & Eucharist:

- Contact Fr. Bo, at least a month in advance if possible

Weddings:

- Contact Fr. Bo, at least a year in advance if possible

Funerals:

- Contact Fr. Bo, as soon as you are able.

Confessions:

- Sundays from 9 till 9:30 with Fr. Bo
- First Sundays of the month with Fr. Myron before and during the Liturgy
- or anytime, just call Fr. Bo to arrange it.

Saint of the Day: from oca.org

Saint Cyril, Archbishop of Alexandria

Commemorated on June 9



Saint Cyril, Archbishop of Alexandria, a distinguished champion of Orthodoxy and a great teacher of the Church, came from an illustrious and pious Christian family. He studied the secular sciences, including philosophy, but most of all he strove to acquire knowledge of the Holy Scriptures and the truths of the Christian Faith. In his youth Cyril entered the monastery of Macarius in the Nitreia hills, where he stayed for six years. Theophilus (385-412), the Patriarch of Alexandria, ordained him as a deacon, numbered him among the clergy and entrusted him to preach.

Upon the death of Patriarch Theophilus, Cyril was unanimously chosen to the patriarchal throne of the Alexandrian Church. He led the struggle against the spread of the Novatian heresy in Alexandria, which taught that any Christian who had fallen away from the Church during a time of persecution, could not be received back into it.

Cyril, seeing the futility of admonishing the heretics, sought their expulsion from Alexandria. The Jews appeared a greater danger for the Church, repeatedly causing riots, accompanied by the brutal killing of Christians. The saint long contended with them. In order to wipe out the remnants of paganism, the saint cast out devils from an ancient pagan temple and built a church on the spot, and the relics of the Holy Unmercenaries Cyrus and John were transferred into it. A more difficult struggle awaited the saint with the emergence of the Nestorian heresy.

Nestorius, a presbyter of the Antiochian Church, was chosen in 428 to the see of Constantinople and there he was able to spread his heretical teaching against the dogma about the uncommingled union of two natures in the Person of the Lord Jesus Christ. Nestorius called the Mother of God not the Theotokos, but rather Christotokos or "Birth-giver of Christ," implying that she gave birth not to God, but only to the man Christ. The holy Patriarch Cyril repeatedly wrote to Nestorius and pointed out his error, but Nestorius continued to persevere in it. Then the saint sent out epistles against Nestorianism to the clergy of Constantinople and to the holy emperor Theodosius the Younger (408-450), denouncing the heresy. Cyril wrote also to other Churches, to Pope Celestine and to the other Patriarchs, and even to monks of several monasteries, warning of the emergence of a dangerous heresy.

Nestorius started an open persecution against the Orthodox. In his presence one of his partisans, Bishop Dorotheus, pronounced an anathema against anyone who would call the Most Holy Virgin Mary the Theotokos.

Nestorius hated Cyril and brought out against him every kind of slander and fabrication, calling him a heretic. The saint continued to defend Orthodoxy with all his powers. The situation became so aggravated, that it became necessary to call an Ecumenical Council, which convened in the city of Ephesus in the year 431. At the Council 200 bishops arrived from all the Christian Churches. Nestorius, awaiting the arrival of Bishop John of Antioch and other Syrian bishops, did not agree to the opening of the Council. But the Fathers of the Council began the sessions with Cyril presiding. Having examined the teaching of Nestorius, the Council condemned him as a heretic. Nestorius did not submit to the Council, and Bishop John opened a "robber council", which decreed Cyril a heretic. The unrest increased....

Saint of the Day: Saint Cyril, Patriarch of Alexandria, continued.....

... By order of the emperor, Patriarch Cyril of Alexandria and Archbishop Memnon of Ephesus were locked in prison, and Nestorius was deposed.

Soon Saints Cyril and Memnon were freed, and the sessions of the Council continued. Nestorius, not submitting himself to the determinations of the Council, was deprived of priestly rank. By order of the emperor he was sent to the faraway place Sasim in the Libyan wilderness, where he died in grievous torments. His tongue, having blasphemed the Mother of God, was overtaken by punishment -- in it there developed worms. Even Bishop John of Antioch and the remaining Syrian bishops signed the decrees of the Council of Ephesus.

Cyril guided the Alexandrian Church for 32 years, and towards the end of his life the flock was cleansed of heretics. Gently and cautiously Cyril approached anyone, who by their own simpleness and lack of knowledge, fell into false wisdom. There was a certain Elder, an ascetic of profound life, who incorrectly considered the Old Testament Priest Melchizedek to be the Son of God. Cyril prayed for the Lord to reveal to the Elder the correct way to view the righteous one. After three days the Elder came to Cyril and said that the Lord had revealed to him that Melchizedek was a mere man.

Cyril learned to overcome his prejudice against the memory of the great John Chrysostom (November 13). Theophilus, the Patriarch of Alexandria, and uncle of Cyril, was an antagonist of John, and presided in a council in judgment of him. Cyril thus found himself in a circle antagonistic to John Chrysostom, and involuntarily acquired a prejudice against him. Isidore of Pelusium (February 4) repeatedly wrote to Cyril and urged him to include the name of the great Father of the Church into the diptychs of the saints, but Cyril would not agree.

Once in a dream he saw a wondrous temple, in which the Mother of God was surrounded by a host of angels and saints, in whose number was John Chrysostom. When Cyril wanted to approach the All-Holy Lady and venerate her, John Chrysostom would not let him. The Theotokos asked John to forgive Cyril for having sinned against him through ignorance. Seeing that John hesitated, the Mother of God said, "Forgive him for my sake, since he has labored much for my honor, and has glorified me among the people calling me Theotokos." John answered, "By your intercession, Lady, I do forgive him," and then he embraced Cyril with love.

Cyril repented that he had maintained anger against the great saint of God. Having convened all the Egyptian bishops, he celebrated a solemn feast in honor of John Chrysostom.

Cyril died in the year 444, leaving behind many works. In particular, the following ought to be mentioned: commentaries On the Gospel of Luke, On the Gospel of John, On the Epistles of the Apostle Paul to the Corinthians and to the Hebrews; also an Apologia in Defense of Christianity against the Emperor Julian the Apostate (361-363). Of vast significance are his Five Books against Nestorius; a work on the Most Holy Trinity under the title Thesaurus, written against Arius and Eunomios. Also two dogmatic compositions on the Most Holy Trinity, distinguished by a precise exposition of the Orthodox teaching on the Procession of the Holy Spirit. Cyril wrote Against Anthropomorphism for several Egyptians, who through ignorance depicted God in human form. Among Cyril's works are also the Discussions, among which is the moving and edifying Discourse on the Exodus of the Soul, inserted in the Slavonic "Following Psalter".

Today we commemorate the repose of this great Father of the Church. He is also remembered on January 18, the date of his flight from Alexandria.



Did you know that we not only have a "Saint of the Day" but we also celebrates an "Icon of the Day" on most days? Today's Icon of the Day is a fairly well known one.

Icon of the Mother of God "of the Passion" a.k.a. "Our Lady of Perpetual Help"

This icon, and it's thousands of copies, are recognized for helping many, many, many,... perhaps countless thousands of people miraculously from illnesses, disasters, invasions, and mental illnesses. In the Icon Christ looks at the instruments of his Passion (the Cross, Spear and Sponge). These items of the Passion frighten Him, but also hold his resolve. He knows that for this reason He became a human. Mary on the other hand looks directly at us who stand before the icon, recognizing that the passion that her Son will need to endure is for our redemption.

If you have an opportunity find an icon of the Theotokos and ask her to bless and help you in both your spiritual and physical life. She never fails to help those who come to her for aid.

TRANSFORM YOUR LIFE. TRANSFORM YOUR PARISH. TRANSFORM THE WORLD.

LAY LEADERSHIP

Are you ready to take your faith to the next level? The Lay Leadership Program is your path to becoming a dynamic leader in your parish.

- 2-year formation program for ministry in catechesis, pastoral outreach, sacramental preparation, etc.
- Six 5-week online courses per year, no exams
- Parish sponsorship
- Program offered in English and Ukrainian

DIACONAL FORMATION

Feeling the call to serve your parish in a more purposeful way? The Diaconal Formation Program will deepen your faith and help you discern a vocation of service to the Church.

- 2-year Certificate in Eastern Theology
- 10 undergraduate courses



Ready to take the first steps in becoming an “active disciple?” Scan the QR code to apply by June 30, 2024.



For the past several weeks Fr. Bo has asked people to pray about taking either or both the “Lay Formation” program, and/or becoming an “Extraordinary Eucharistic Minister” in our parish. I hope you have all been doing this seriously. The time has come for us to make the call(s).

What is the “Lay* Formation” program that the Eparchy has put together?**

“Lay formation” is, pretty much as the name suggests, a program for the formation of the laity* in the faith and traditions of the Church.

Bishop David and his Pastoral Centre staff have worked together with Newman Theological College to create a 2 year program which is given from the Eastern Catholic faith perspective. There are NO EXAMS, but there will be short reflection papers.

In the first year of the program those enrolled work on the “Eastern Christian Tradition I” Certificate. This certificate only offered every other year has six different ‘5 week’ courses. These are:

- **Scripture** (Sep 16 - Oct. 20);
- **The Theology of Eastern Christianity Part 1** (Oct 28 - Dec 1);
- **The Theology of Eastern Christianity Part 2** (Jan 6 - Feb 9);
- **Worship and Spirituality of Eastern Catholic Churches Part 1** (Feb 17 - Mar 23);
- **The Holy Mysteries: an Introduction** (Mar 31 - May 4); and
- **Worship and Spirituality of Eastern Catholic Churches Part 2** (May 12 - Jun 15).

Then the following year (2025-26) you get to choose to either take “Eastern Christian Lay/Diaconate Formation Year 2 - Catechesiss” or “Eastern Christian Lay/Diaconate Formation Year 2 - Pastoral Care” which similarly is another 6 - ‘5 week’ courses. (You can see the courses on Newman Theological College’s website newman.edu)

Each course is only \$90 plus textbook(s), but bishop is hoping that parishes like ours “invest” in their parishioners, so that they can in return help the rest of the parish grow through various programs. Our PPC will be encouraged to assist in the financial costs of all those who enrol in our parish. How much support will be forthcoming depends on how many take up the invitation.

* “Lay people” or “the Laity” literally means those not ordained. So most of the people in the church, including likely you, are “laity”.

** The program is technically called the “Lay Formation / Diaconal Program” for our Eparchy, as those who are considering the diaconate would also be studying with other lay people. Diaconal candidates would need to do more than just the two years before becoming ordained however.

What does it mean to be an “Extraordinary Eucharistic Minister”?

The normal Eucharistic Minister is a priest. It is the priests job to distribute the Eucharist. However in many parishes the priest would struggle to do this without help. Therefore Deacons and other “Extraordinary Eucharistic Ministers” are asked to help distribute the Eucharist.

Our parish has a few “**Lectors**” who were ordained by then Bishop, now Metropolitan, Lawrence. Lectors are really ordained to read the Epistles and Old Testament readings during church services. However when Bishop Lawrence ordained these people, it was his intention that they assist the parishes in the distribution of the Eucharist.

Currently we have 2 active Lectors (Ed and Everett). However due to normal life, sometimes these two people are not always available to help. Which leaves a greater load on the Priest and Deacon (if the deacon is there).

Bishop David recognizes the need for “Extraordinary Eucharistic Ministers” but instead of ordaining them as Lectors, he instead directly gives them the blessing to distribute the Eucharist when needed.

In order to be able to distribute the Eucharist well, you would need to understand well Who the Eucharist is, how to properly distribute the Eucharist and you would need to be a respected part of the community.

In order to prepare people to be EEMs (I cant keep writing the whole thing out) Fr. Bo would have a few in house sessions before recommending the people to Bishop, and inviting Bishop David to commission them within the parish on a Sunday.

Distributing Eucharist is not exclusive to one gender. Both men and women can be EEMs.

I imagine that those who would be commissioned would have a schedule of when they would be serving. The frequency of serving would depend on how many people take up the invitation.

If the Fire Alarm went off in our Church, would you know what to do?

The answer is, calmly and quickly remove yourself and any people needing assistance from the building through the nearest exit and then go to the "Muster Point". Simple.

The "Muster Point" is a spot outside where people meet in the case of Emergency so that they are safely away from the building and not in the way of the Emergency responders. **In our case the Muster Point is at the BACK OF OUR PARKING LOT.** We can not meet at the front of the Parking Lot as that is where the Fire Trucks will need to enter and hook up to the hydrant.

Please be familiar with the locations of all the fire exits, pull stations and fire extinguishers by looking at the maps posted in various locations within the building. These maps are also found on this bulletin below for your convenience today.

If you discover a fire in the building and it is possible to put out, extinguish it. Fire extinguishers are clearly marked on these maps.

If you discover a fire that is not manageable, immediately pull the nearest fire Pull Station, then exit the building. If you are the last person exiting then close doors behind you.

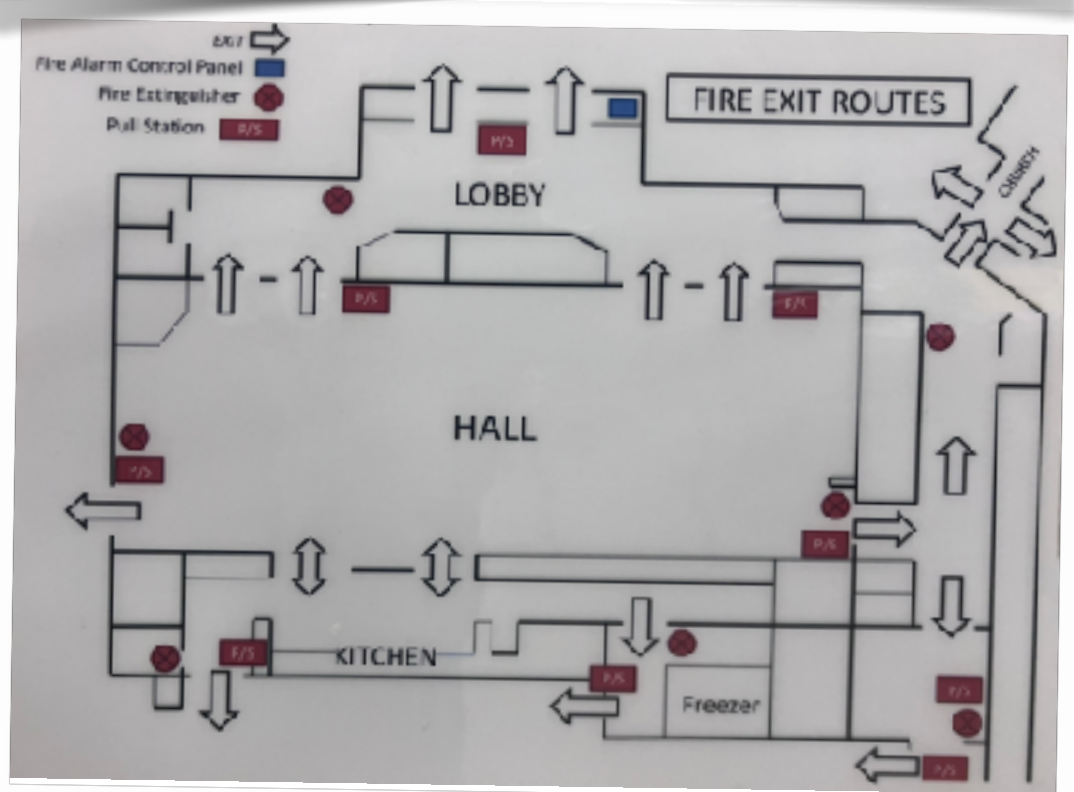
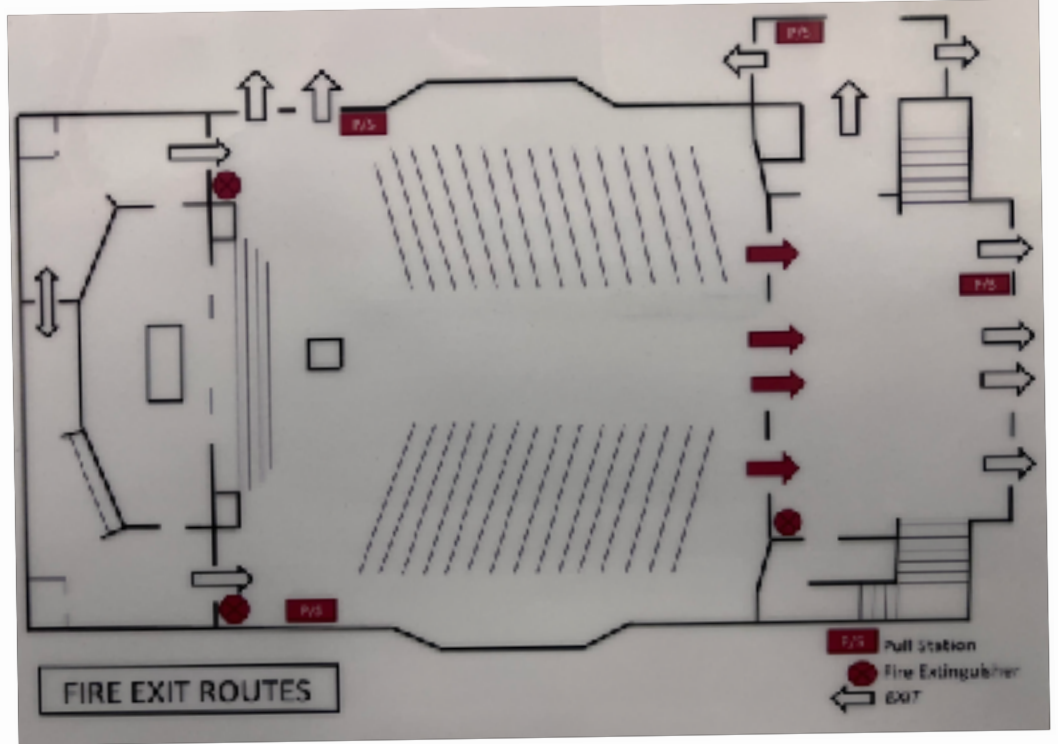



Summer Solstice Supper & Dance

JUNE 22ND



HOLY CROSS UKRAINIAN CATHOLIC PARISH

9003 - 153 AVENUE NW, EDMONTON

COCKTAILS AT 5PM

Dinner at 6pm Ukrainian Feast by Legends Catering
Entertainment by St. Albert DanceCo Ukrainian Dancers 8pm

Live music and dance at 9pm by Mike and the Relics
Adult ONLY

Bar proceeds to Holy Cross Men's Club

Late night snacks
\$50/person

Contact: Lisa 780-222-9155



Upcoming Meetings & Events:

- **Unknown date, but soon:** In the near future our parish will be having a “Fire Drill”. This is likely to happen on a day when many parishioners are in the parish (likely a Sunday). Which one? Will it be today?
- **Sunday, June 9th after Liturgy:** we will be blessing the new **Parish Pastoral Council** and taking their group photo.
- **Friday, June 14th at 1:30:** There will be a funeral for the handmaiden of God + **Anne Popowich** at Park Memorial Funeral Home. Anne was a parishioner at our parish for years before going to St. Michael’s Extended Care Centre. Our prayers are with her and her family. Vichnaya Pamyat.
- **Likely Saturday, June 15:** There will likely be a funeral for the servant of God + **Matthew Tanouya** in St. Paul, AB. They have asked if Fr. Bo can serve at the funeral. Our prayers are with Matthew and his family. Vichnaya Pamyat.
- **Saturday, June 15th at 11 am:** The Eparchial **Ukrainian Catholic Women’s League of Canada** invites all members and guests to the celebration of the 80th Anniversary of the UCWLC at the parish of the Exaltation of the Holy Cross. Moleben at 11 am, Lunch & program to follow. The cost of luncheon is \$25 per person. Please respond to Dianne Kluk by June 1st.
- **Wednesday, June 19th: Nalysnyky Bee.** We are making Nalysnyky for the parish to use and sell. If you are interested in helping please contact Lasha. If you don’t know who Lasha is... just ask around.
- **Saturday, June 22nd: “Summer Solstice Supper and Dance”** here in our hall. Live music will be provided by “Mike and the Relics”. Save that date. You won’t want to miss this great party! (More details to come soon.)
- **Sunday, June 23rd:** Last **Sunday School** Class till September. We will start back up with Sunday School on September 8th, since the 1st is the long weekend.
- **Monday, June 24th: Potato and Dough Prep.** We are making Perogies for the parish to use and sell on the following day. If you are interested in helping please contact Lasha. If you don’t know who Lasha is... just ask around.
- **Monday, June 25th: Perogy Bee.** We are making Perogies for the parish to use and sell. If you are interested in helping please contact Lasha. If you don’t know who Lasha is... just ask around.
- **Saturday, June 29th: Big feast day! Sts. Peter and Paul.** 10 am Divine Liturgy.
- **Sunday, June 30th:** Next **Kid’s Liturgy**. Please invite your kids and grandkids to join you at church this day.
- **First Sunday of Each Month:** Fr. Myron is here to hear **confessions**. Let’s take advantage of this opportunity and return ourselves with our Lord.
- **The first Tuesday of each month at 10:30 am** (unless otherwise stated in this bulletin): **Divine Liturgies at Venta Care Centre.**
- **Saturday July 6:** Fr. Bo does **Wedding** for Tyler & Mariah at Cathedral
- **June 30 - July 5: Camp Oselia** Week 1. Discover the mystery of Jesus at our Ukrainian Catholic Camp **for children aged 8-14**, enjoy a week full of faith, fun, and fellowship with activities like swimming, archery, and more. Bilingual staff ensure a welcoming environment for all. Limited spots – Register now at "www.camposelia.com"!

Interested in volunteering or have other questions about Camp Oselia? Contact Deacon Cyril at deacon.kennedy@eeparchy.com
- **July 1-13: Camp St. Basil’s** (two weeks). Registrations have closed.
- **July 7-12: Camp Oselia** Week 2. Discover the mystery of Jesus at our Ukrainian Catholic Camp **for children aged 8-14**, enjoy a week full of faith, fun, and fellowship with activities like swimming, archery, and more. Bilingual staff ensure a welcoming environment for all. Limited spots – Register now at "www.camposelia.com"!

Interested in volunteering or have other questions about Camp Oselia? Contact Deacon Cyril at deacon.kennedy@eeparchy.com
- **Saturday, July 13th at 2 pm: Wedding** here at Holy Cross for Austin & Brittany. (Reception not here). The “Rehearsal” will take place on the Friday beforehand.
- **July & August:** We will continue with our regular Sunday 9:30 am **Rosary** schedule till the end of June. During the summer months, people are welcome to continue praying the Rosary, either quietly or aloud, but there will be no scheduled leaders.
- **July & August:** Likewise we will continue our weekly **Sunday Coffee Hour** till the end of June. Then we will take a pause for the summer months.
- **August 5-10: Altar Boy Camp.** See poster on page 4.
- **Saturday, August 10: Hall rental.**
- **Mid August: Fr. Bo will be away** for an Iconography Workshop (this time he is taking it, not giving it).
- **Sunday, September 15th:** Bishop David has put this date on his calendar to visit our parish for our **PRAZNYK** (the feast of the Elevation of the Holy Cross is on the 14th).
- **September 28: The Perogy Supper Committee is going ahead with the Perogy Supper.** More information will be coming via the bulletin, posters, and sign prior to tickets going on sale. If anyone is interested in helping with the event, please see or call Lasha 780 288 4880 or Terry 780 456 2828.

Parish News:

- Holy Cross Parish received the payment for **our last Casino** (January 2024). We received **\$77,877.48**. A big thank you to all the volunteers who helped work the Casino. This money helps puts us in a better financial position. The Casino is one of Holy Cross' major fundraising projects.
- Are you interested in **joining our parish officially?** Speak to J'lynn. If you don't know who she is, talk to Fr. Bo and he'll introduce you to her, or get you in contact with her.
- We are **recording our Liturgies** for those who are not able to come in person to church. Please note that the recorded Liturgies are not intended to be an option for those who simply want to stay at home.
- **The people of Ukraine continue to need your help.** As the war continues in Ukraine, millions of the country's inhabitants are in dire straits often lacking the basic necessities of life. As part of your personal sacrifice, kindly consider making a donation towards providing emergency services and humanitarian and pastoral support to Ukrainians by offering care, medical supplies, food, clothing and shelter to displaced persons, the elderly and the sick, as well as educational programs and support to local priests.
 - For just \$25, an emergency food package can provide much needed relief. Donations may be made through our local parish, the Eparchy of Edmonton (www.eeparchy.com), or directly to Catholic Near East Welfare Association - Canada (cnewa.ca). May God bless you and your family for your generosity.

Help Wanted & Parish Requests

- **Would you consider reading the Epistle** during Liturgies sometimes? If you are interested let Fr. Bo know and he will pass your names on to those who currently organize this important ministry.
- At the last council meeting a **Perogy Supper Committee** was setup to look into the possibility of doing a Perogy Supper in the fall of 2024. If anyone is interested in helping with the event, please see or call Lasha 780 288 4880 or Terry 780 456 2828.
- Ladies' Group members, please check the **Prayer Partners** on the bulletin board as some of them have changed in the recent weeks.
- Come **be on a Greeter and Coffee Hour team**. Simply call Diana Horyn at 780-455-9926.
- **BINGO !!** The team of bingo volunteers is in dire need of new volunteers willing to step up and support this reliable fundraiser. Please call our volunteer chairperson, Darlene @ 780-476-8797.
- If you are able to **help with upcoming funerals** in any way, including in the kitchen to help prepare the lunches, talk to Fr. Bo or those in charge of the ministry that you are wanting to help with.

Educational Opportunity

- **CHRISTIAN FAMILY MOVEMENT** (for Ukrainian Speakers) - **ХРИСТИАНСЬКИЙ РУХ СІМЕЙ** – наступна лекція відбудеться в суботу, 8-го червня, о год. 7:00 вечора (після Вечірні), в парафії Успіння Пресвятої Богородиці, 15608 104 Авеню. Паралельна програма для дітей. ТЕМА: Збереження єдності в шлюбі – Як практично укріпити подружню єдність; як пізнавати та уникати те, що роз'єднює. Запрошуємо всіх подруж до участі! За дальшими інформаціями, просимо дзвонити на тел. 780-489-8868.
- You are invited to participate in an exciting program coming up this summer called **"the Ukrainian Sacred Music Workshop"**. It will take place from July 31 to August 4 at All Saints Camp in Emlenton, Pennsylvania. Participants will be able to sing Ukrainian choral compositions by the likes of Vedel, Berezovsky, and Bortniansky. They will also have a chance to network with fellow liturgical singers from around the world. This year's musical director will be Melita Mudri-Zubacz, who has decades of experience and higher education in Eastern liturgical conducting. Ages 14 +. More information can be found at www.banduracamp.org/ukrainiansacredmusic.



June 30 - July 5
July 7 - 12
Registrations going fast
Camposelia.ca

Camp Oselia
God's Playground



Hey Young Adults

(and middle aged ones too)

Shall we do another
"Young Adult
Ministry" Night soon?

Call or Text Fr. Bo or
talk to him in person.

Ukrainian Catholic Eparchy of Edmonton Altar Boy Camp August 5th to August 10th, 2024

Camp St. Basils @ Pigeon Lake, AB

The Altar Boys of the Ukrainian Catholic Eparchy of Edmonton serve an integral part in our church celebrations and again are given an opportunity to attend the Annual Altar Boy Camp to learn more about their church, faith, and each other. The camp will offer spiritual, cultural, recreational activities and great food!

WHO IS INVITED TO ATTEND?

- ❖ All active Altar Boys of the Ukrainian Catholic Eparchy 7 years and older
- ❖ Boys of the Ukrainian Catholic Eparchy wishing to become active Altar Boys and who have not had an opportunity to learn to serve.



Please bring a rosary

CAMP DATES

Monday, August 5th, 2024

- ❖ Camp Registration: 3:00 – 4:30 p.m.
- ❖ Supper for Altar Boys and Staff: 6:00 p.m.

August 6th – August 9th, 2024

- ❖ Daily Program Activities: Liturgy, Religious Instruction, Sports/Waterfront Activities, and Crafts

Saturday, August 10th, 2024

- ❖ 10:30 a.m. Liturgy for campers, parents, and staff
- ❖ Closing of Camp and pick-up of Acolytes by 12 noon.

CAMP INFORMATION

Spiritual Director: Father Thomas Kobak, OSBM fr.kobak@eeparchy.com
Telephone: (780) 434 8010

General Information: Ken Stelmach kenstelmach@hotmail.com

REGISTRATION

<https://form.jotform.com/241278514682259>



\$400.00 per Altar Boy camper

The Next Couple Weeks at Holy Cross

Please let Fr. Bo know of any mistakes or if he is missing something.

Sunday	Monday	Tuesday	Wednesday	Thursday	Friday	Saturday
<p>9</p> <p>Third Sunday after Pentecost. Octoechos Tone 2. Our Holy Father Cyril, Archbishop of Alexandria (444). Apostles' Fast. Romans 5:1-10. Matthew 6:22-33.</p> <p>9:30 am Rosary</p> <p>10 am Divine Liturgy</p> <p>Yes Sunday School, Yes Coffee Hour</p> <p>Blessing of the New Parish Pastoral Council</p>	<p>10 </p> <p>Holy Priest-Martyr Timothy, Bishop of Prussa (361-63). Apostles' Fast. Romans 9:18-33. Matthew 11:2-15.</p> <p>10 am Bible Study</p> <p>4:30 Marriage Prep</p>	<p>11 </p> <p>Holy Apostles Bartholomew and Barnabas. Apostles' Fast. Acts 11:19-30. Luke 10:16-21.</p> <p>11 am Appointment</p> <p>3:45 pm Appointment</p> <p>4 pm Sacred Orders Commission Meeting at Pastoral Centre</p>	<p>12 </p> <p>Our Venerable Father Onuphrius the Great (c. 337). Our Venerable Father Peter of Athos (892). Krystynopil Icon of the Mother of God. Apostles' Fast. Abstinence from meat and foods that contain meat. Romans 11:2-12. Matthew 11:20-26.</p> <p>9 am Divine Liturgy</p> <p>10 am Baptismal Prep</p> <p>1 pm Appointment</p>	<p>13 </p> <p>Holy Martyr Aquilina (286-305). Holy Triphillius, Bishop of Leucosia (Nicosia) on Cyprus (343). Venerable Father Anthony of Padua. Apostles' Fast. Romans 11:13-24. Matthew 11:27-30.</p> <p>5:30 pm Appointment</p> <p>Please have all bulletin items submitted by the end of Thursday if possible.</p>	<p>14 </p> <p>Holy Prophet Elisha (9th c. BC). Our Holy Father Methodius, Patriarch of Constantinople (847). Apostles' Fast. Abstinence from meat and foods that contain meat. Romans 11:25-36. Matthew 12:1-8.</p> <p>1:30 pm Funeral for + Anne Popowich at Park Memorial Funeral Home</p> <p>Kitchen Rental</p> <p>5:30 pm Appointment</p>	<p>15 </p> <p>Holy Prophet Amos (8th c. BC). Venerable Jerome, Presbyter of Stridonium (420). Apostles' Fast. Romans 6:11-17. Matthew 8:14-23.</p> <p>Eparchial UCWLC Luncheon at Holy Cross</p> <p>Probable Funeral for + Matthew Tanouya in St. Paul, AB</p> <p>Usual Bulletin writing and prep for Sunday day.</p>
<p>16</p> <p>Fourth Sunday after Pentecost. Octoechos Tone 3. Our Holy Father and Wonderworker Tychon of Amathus (408-50). Apostles' Fast. Romans 6:18-23. Matthew 8:5-13.</p> <p>9:30 am Rosary</p> <p>10 am Divine Liturgy</p> <p>Yes Sunday School, Yes Coffee Hour</p>	<p>17 </p> <p>Holy Martyrs Manuel, Sabel and Ismael. Our Venerable Father Hypatius, Hegumen of Ruphenia (446). Apostles' Fast. Romans 12:4-5, 15-21. Matthew 12:9-13.</p> <p>10 am Bible Study</p>	<p>18 </p> <p>Holy Martyr Leontius (69-79). Apostles' Fast. Romans 14:9-18. Matthew 12:14-16, 22-30.</p> <p>9 am Graduation Mass for Gr. 6 Students at Ann Fitzgerald School</p> <p>Parish Bingo Fundraiser</p>	<p>19 </p> <p>Holy Apostle Jude, Brother of the Lord According to the Flesh. Polyeleos Feast. Apostles' Fast. Abstinence from meat and foods that contain meat. Jude 1:1-10. John 14:21-24.</p> <p>9 am Divine Liturgy</p> <p>10 am Baptismal Prep</p> <p>9 am Nalysnyky Bee</p>	<p>20 </p> <p>Holy Priest-Martyr Methodius, Bishop of Patara (311). Apostles' Fast. Romans 15:17-29. Matthew 12:46-13:3.</p> <p>5:30 pm Appointment</p> <p>Please have all bulletin items submitted by the end of Thursday if possible.</p>	<p>21 </p> <p>Holy Martyr Julian of Tarsus (284-305). Apostles' Fast. Abstinence from meat and foods that contain meat. Romans 16:1-16. Matthew 13:3-9.</p> <p>Kitchen Rental</p> <p>5:30 pm Appointment</p>	<p>22 </p> <p>Holy Priest-Martyr Eusebius, Bishop of Samosata (379-80). Apostles' Fast. Romans 8:14-21. Matthew 9:9-13.</p> <p>Summer Solstice Supper & Dance</p> <p>Usual Bulletin writing and prep for Sunday day.</p>
<p>23</p> <p>Fifth Sunday after Pentecost. Octoechos Tone 4. Holy Martyr Agrippina. Apostles' Fast. Romans 10:1-10. Matthew 8:28-9:1.</p> <p>9:30 am Rosary</p> <p>10 am Divine Liturgy</p> <p>Yes Sunday School (the last one till fall), Yes Coffee Hour</p>	<p>24 </p> <p>Nativity of the Honourable and Glorious Prophet John, Forerunner and Baptist of Christ. All-Night Vigil Feast. Apostles' Fast. Romans 13:11b-14:4. Luke 1:1-25, 57-68, 76, 80.</p> <p>9 am Potato and Dough Prep (for Perogies)</p> <p>7 pm PPC Meeting</p>	<p>25 </p> <p>Holy Venerable-Martyr Febronia. Apostles' Fast. 1 Corinthians 1:1-9. Matthew 13:24-30.</p> <p>9 am Perogy Bee</p> <p>1:20 Appointment</p>	<p>26 </p> <p>Our Venerable Father David of Thessalonica (c. 530). Passing into Eternal Life (1941) of Blessed Mykola (Nicholas) Konrad, Pastor of Stradch, Founder of Obnova, Professor of the Lviv Theological Academy, and Martyr. Passing into Eternal Life (1941) of Blessed Volodymyr Pryjma, Cantor of Stradch and Martyr. Passing into Eternal Life (1941) of Blessed Andrii Ishchak, Pastor of Sykhiv, Professor of the Lviv Theological Academy, and Martyr. Apostles' Fast. Abstinence from meat and foods that contain meat. 1 Corinthians 2:9-3:8. Matthew 13:31-36.</p> <p>9 am Divine Liturgy</p> <p>10 am Baptismal Prep</p>	<p>27 </p> <p>Bishop-Martyr Nykolai (Nicholas) Charnetsky and the Twenty-Seven Other New Blessed of the Church of Rus-Ukraine Beatified in 2001. Our Venerable Father Samson, Host of Strangers (527-65). Polyeleos Feast. Apostles' Fast. Ephesians 6:10-17. Luke 21:12-19.</p> <p>5:30 pm Appointment</p> <p>Please have all bulletin items submitted by the end of Thursday if possible.</p>	<p>28 </p> <p>Transfer of the Relics of the Holy Unmercenary Cyrus and John (5th c.). Apostles' Fast. Abstinence from meat and foods that contain meat. 1 Corinthians 4:5-8. Matthew 13:44-54.</p> <p>5:30 pm Appointment</p> <p>Last day of Apostles' Fast</p>	<p>29</p> <p>Holy, Glorious, All-Praiseworthy and Chief Apostles Peter and Paul. Passing into Eternal Life (1941) of Blessed Iakym (Joachim) (Senkivsky), Basilian Protohegoumen and Martyr of Drohobych, where his body was boiled. All-Night Vigil Feast. A day when the faithful are highly encouraged to participate in the Divine Liturgy. 2 Corinthians 11:21-12:9. Matthew 16:13-19.</p> <p>10 am Festal Divine Liturgy</p> <p>Mundare Vidpust</p>